

# ALLEGATO DISEGNI

## Deumidificatori orizzontali e verticali

con recuperatore ad altissima efficienza

**RER**  
**REV**

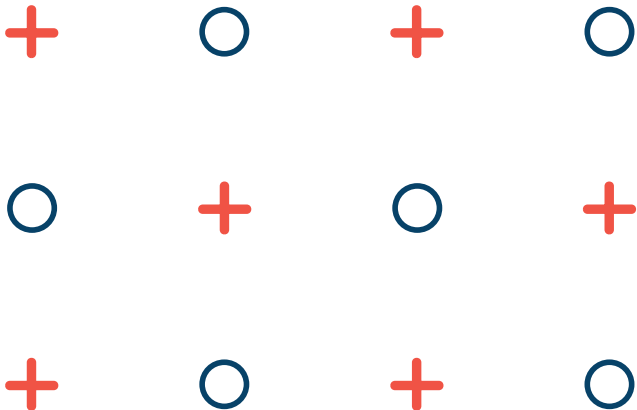



## SOMMARIO

<b>1</b>	<b>DISEGNI DIMENSIONALI .....</b>	<b>4</b>
1.1	RER 015 .....	4
1.2	RER 020 .....	5
1.3	RER 035 .....	7
1.4	RER 050 .....	9
1.5	RER 100 .....	11
1.6	REV 020 .....	14
1.7	REV 035 .....	16
1.8	REV 050 E REV 070 .....	18





**1.2.2 Plenum di mandata RER 020**

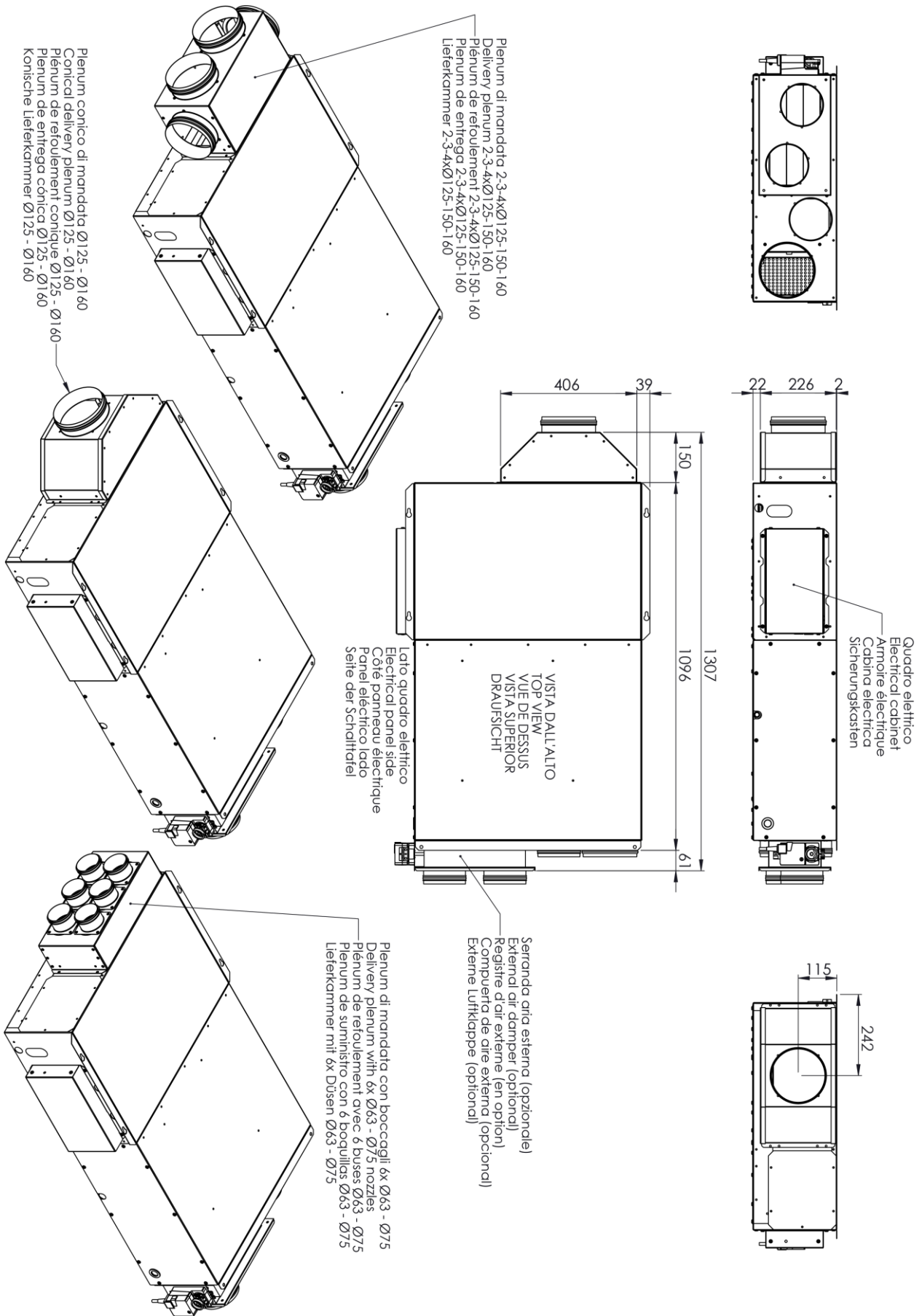

### 1.3 RER 035

#### 1.3.1 Dimensionale RER 035 (tutte le versioni)

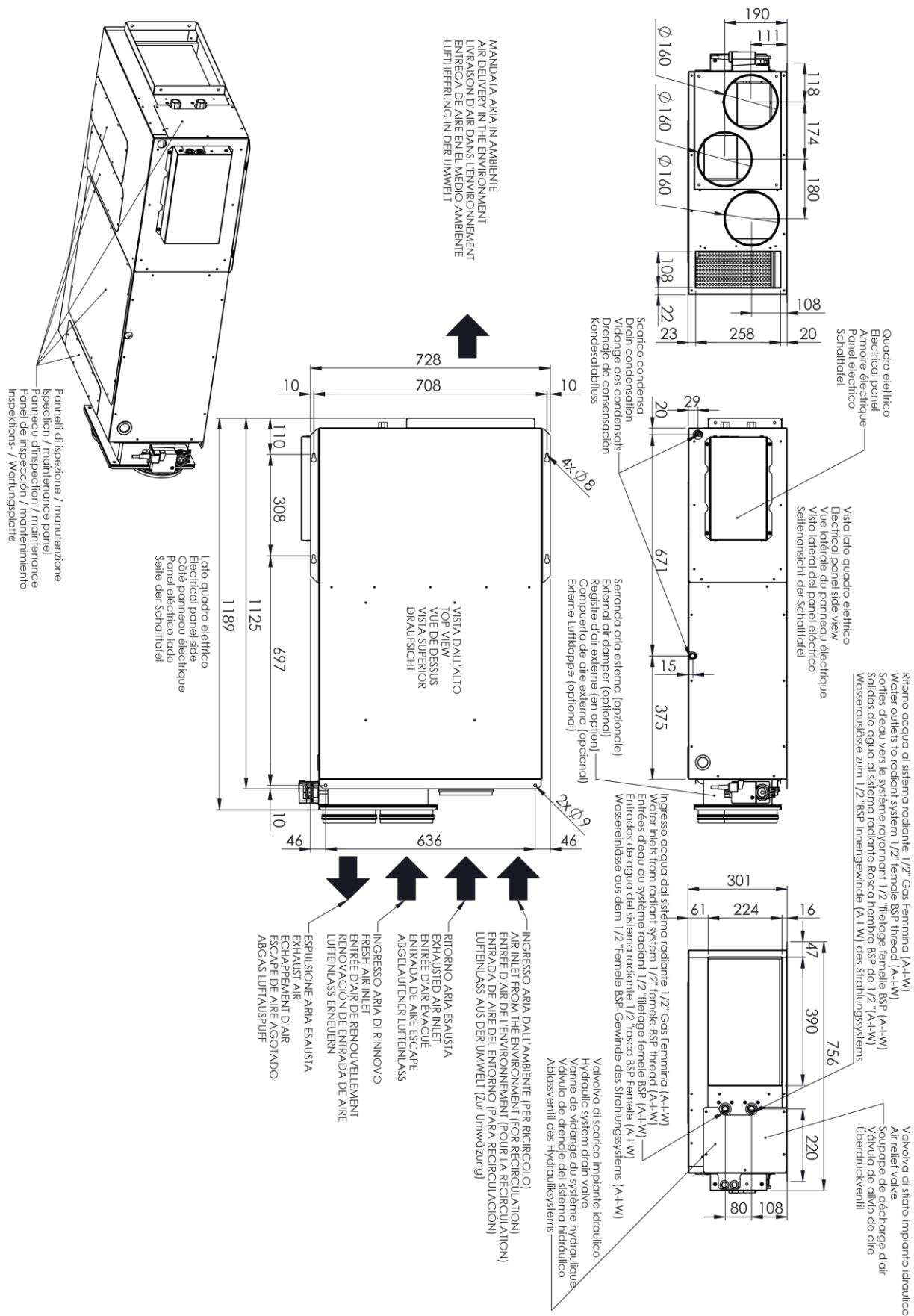

**1.3.2 Plenum di mandata e di ricircolo RER 035**

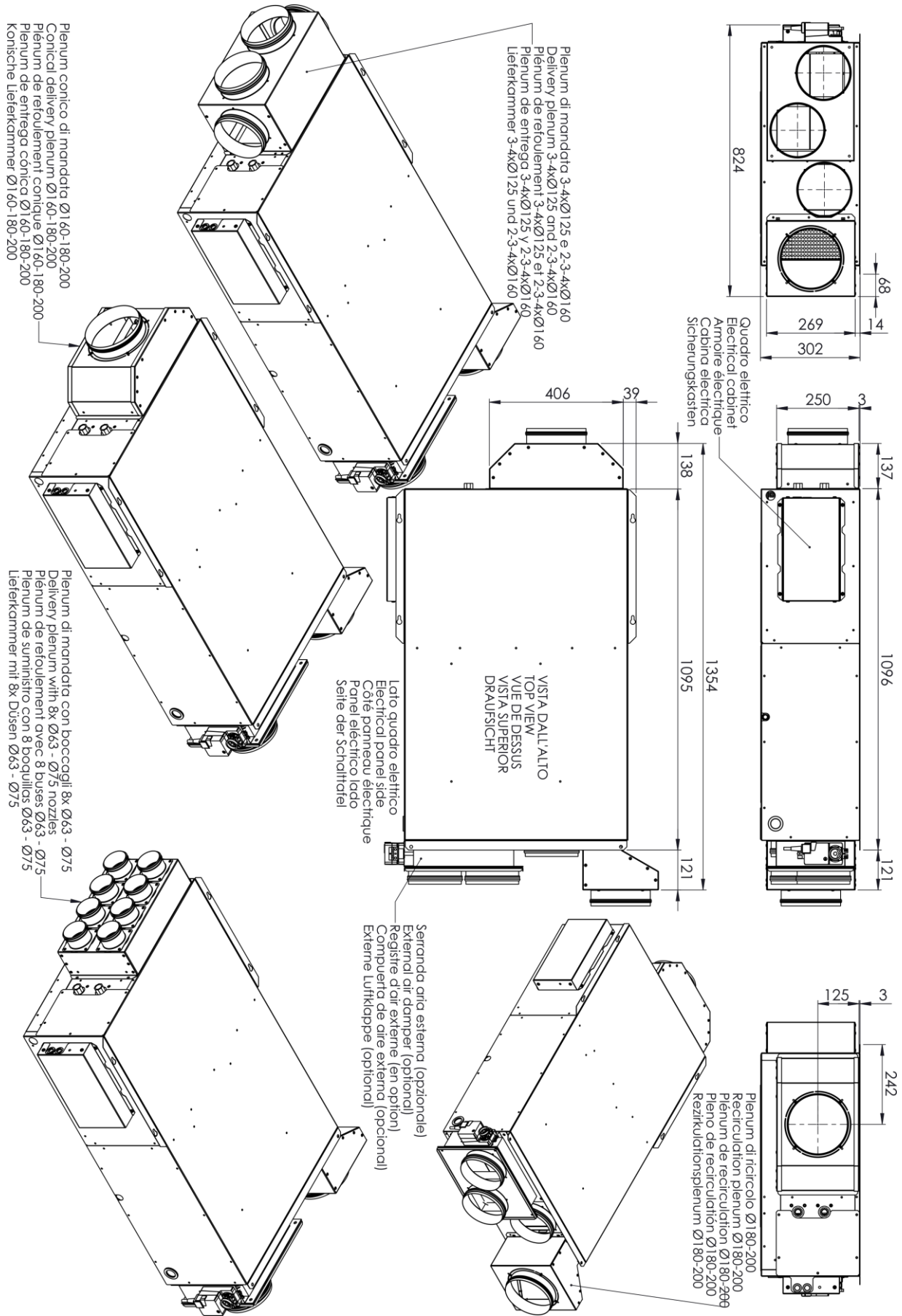



1.4.2 Plenum di mandata e di ricircolo RER 050

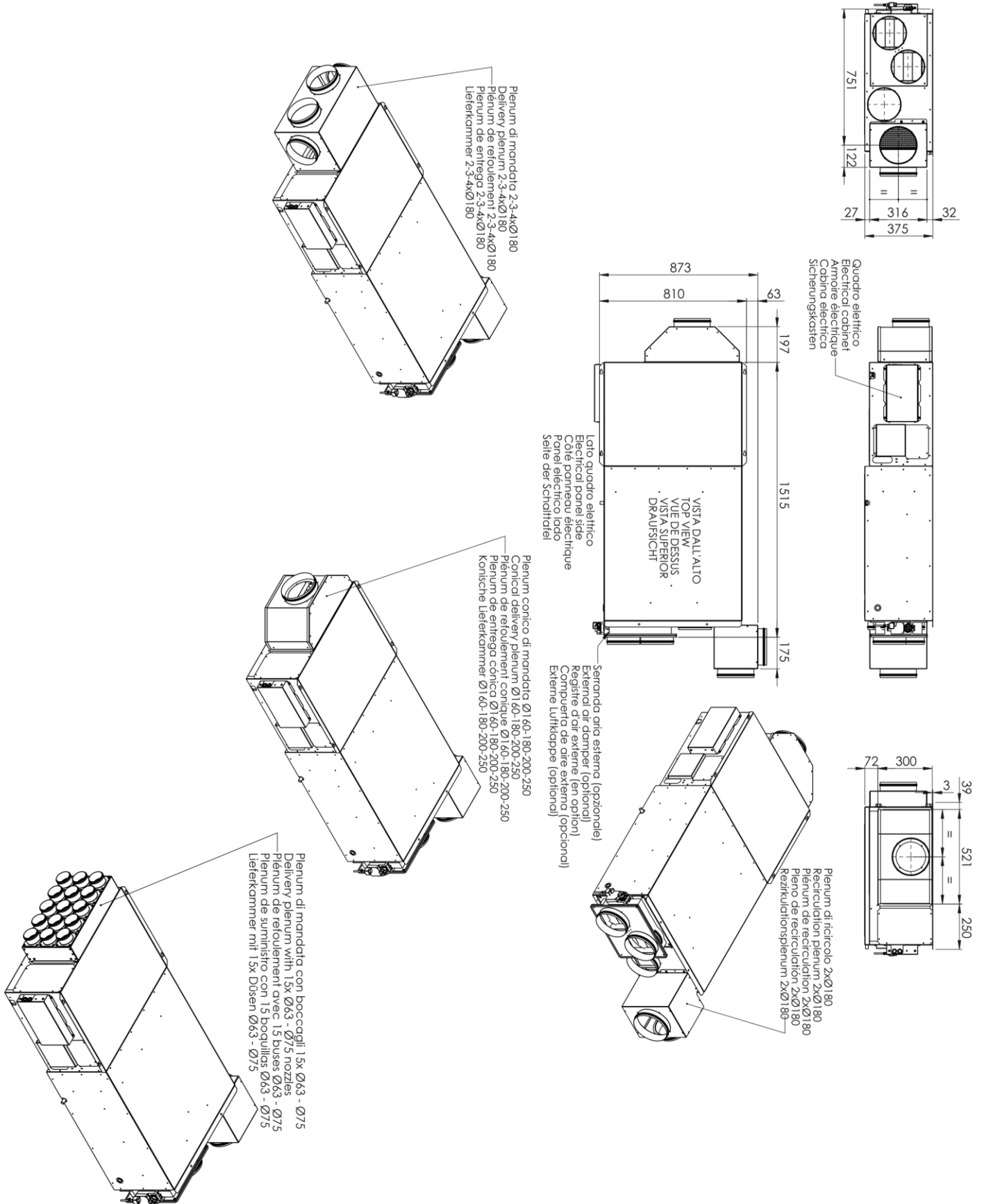

## 1.5 RER 100

### 1.5.1 Dimensionale RER 100 (tutte le versioni)

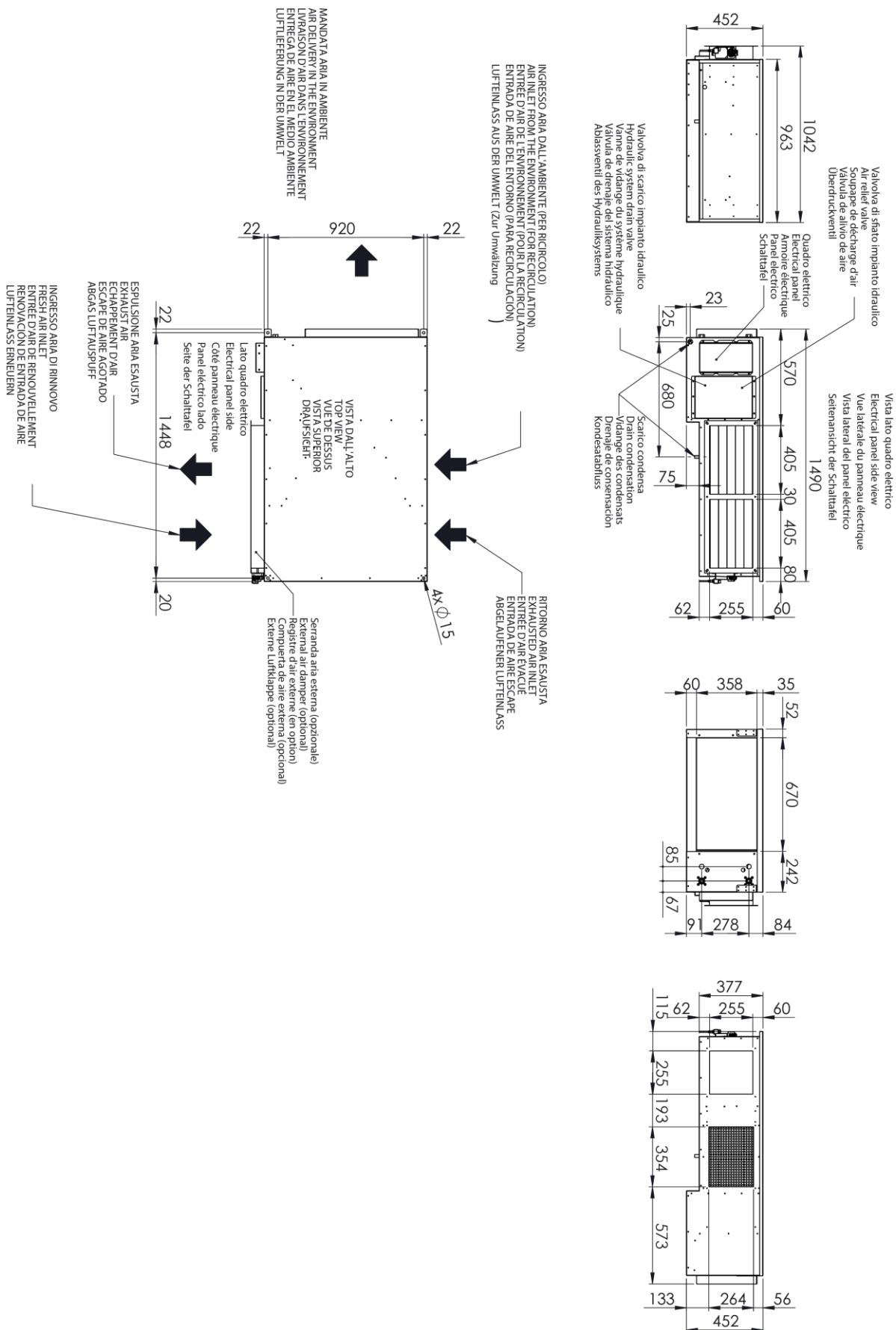

Pannelli di ispezione / manutenzione  
Inspection / maintenance panel  
Panneau d'inspection / maintenance  
Panel de inspection / mantenimiento  
Inspektors- / Wartungsplatte

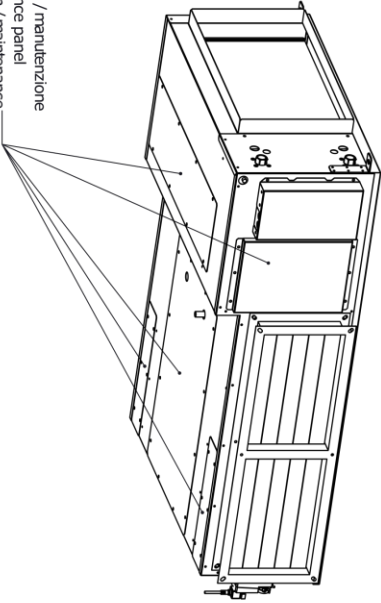

Ritorno acqua al sistema radiante 1/2" Gas Femmina (I)  
Water outlets to radiant system 1/2" Female BSP thread (I)  
Sortes d'eau vers le système rayonnant 1/2" filetage femelle BSP (I)  
Salidas de agua al sistema radiante Rosca hembra BSP de 1/2" (I)  
Wasseranschlüsse zum 1/2" BSP-fingergewinde (I) des Strahlungssystems

Ingresso acqua del sistema radiante 1/2" Gas Femmina (I)  
Water inlets from radiant system 1/2" Female BSP thread (I)  
Entrées d'eau du système radiant 1/2" filetage femelle BSP (I)  
Entradas de agua del sistema radiante 1/2" rosca BSP Femelle (I)  
Wasseranschlüsse aus dem 1/2" Femelle BSP-Gewinde des Strahlungssystems (I)

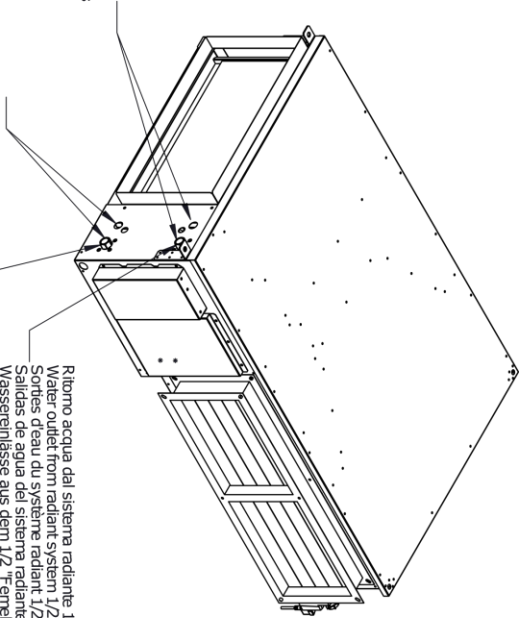

Ritorno acqua dal sistema radiante 1/2" Gas Femmina (A) - 3/4" Gas Femmina (W)  
Water outlet from radiant system 1/2" Female BSP thread (A) - 3/4" Female BSP thread (W)  
Sortes d'eau du système radiant 1/2" filetage femelle BSP (A) - 3/4" filetage femelle BSP (W)  
Salidas de agua del sistema radiante 1/2" rosca BSP Femelle (A) - 3/4" rosca BSP Femelle (W)  
Wasseranschlüsse aus dem 1/2" Femelle BSP-Gewinde des Strahlungssystems (A) - 3/4" Femelle BSP-Gewinde des Strahlungssystems (W)

Ingresso acqua dal sistema radiante 1/2" Gas Femmina (A) - 3/4" Gas Femmina (W)  
Water inlets from radiant system 1/2" Female BSP thread (A) - 3/4" Female BSP thread (W)  
Entrées d'eau du système radiant 1/2" filetage femelle BSP (A) - 3/4" filetage femelle BSP (W)  
Entradas de agua del sistema radiante 1/2" rosca BSP Femelle (A) - 3/4" rosca BSP Femelle (W)  
Wasseranschlüsse aus dem 1/2" Femelle BSP-Gewinde des Strahlungssystems (A) - 3/4" Femelle BSP-Gewinde des Strahlungssystems (W)

1.5.2 Plenum di mandata e di ricircolo RER 100

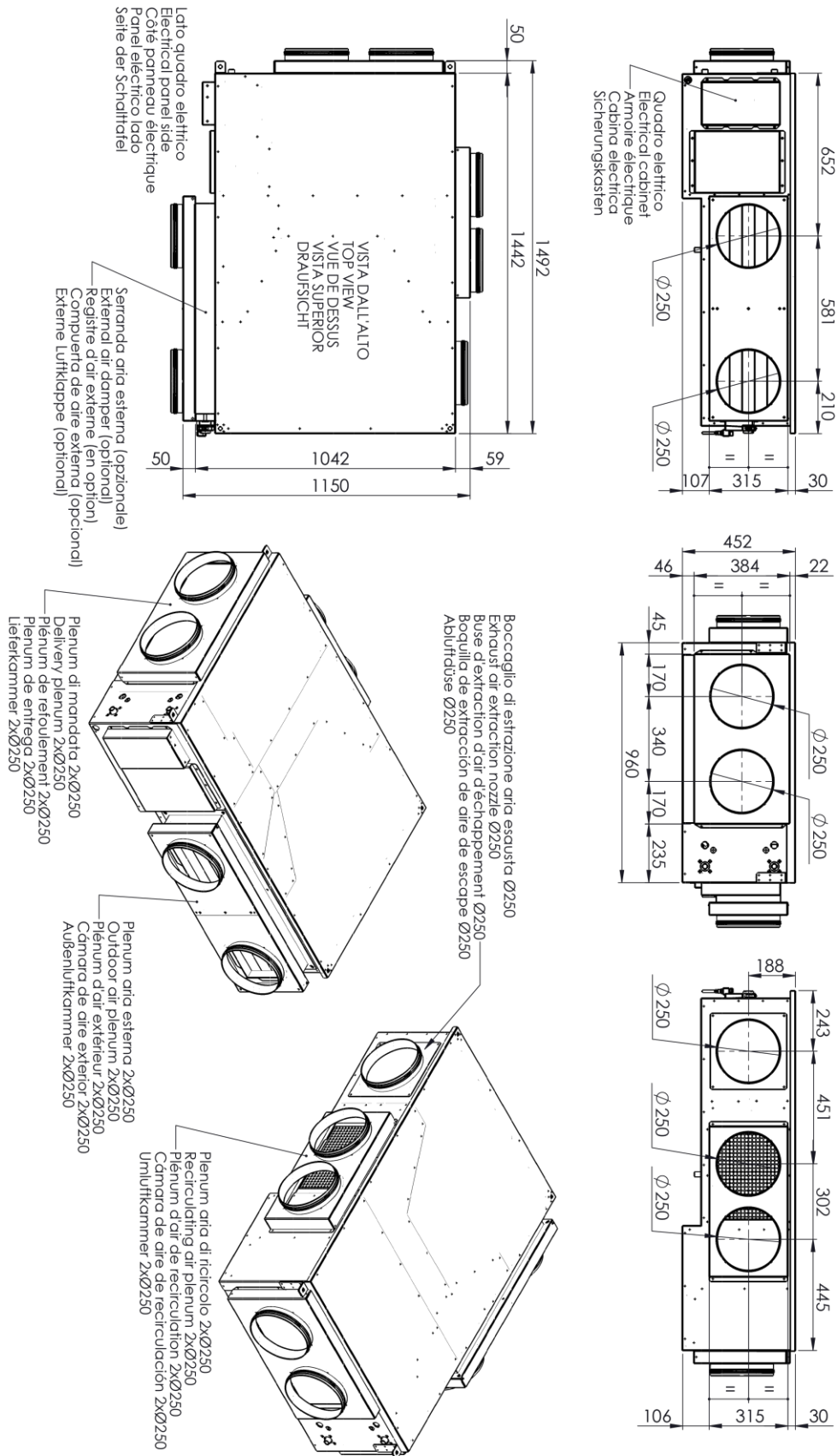



1.6.2 Dimensionale plenum ricircolo REV 020

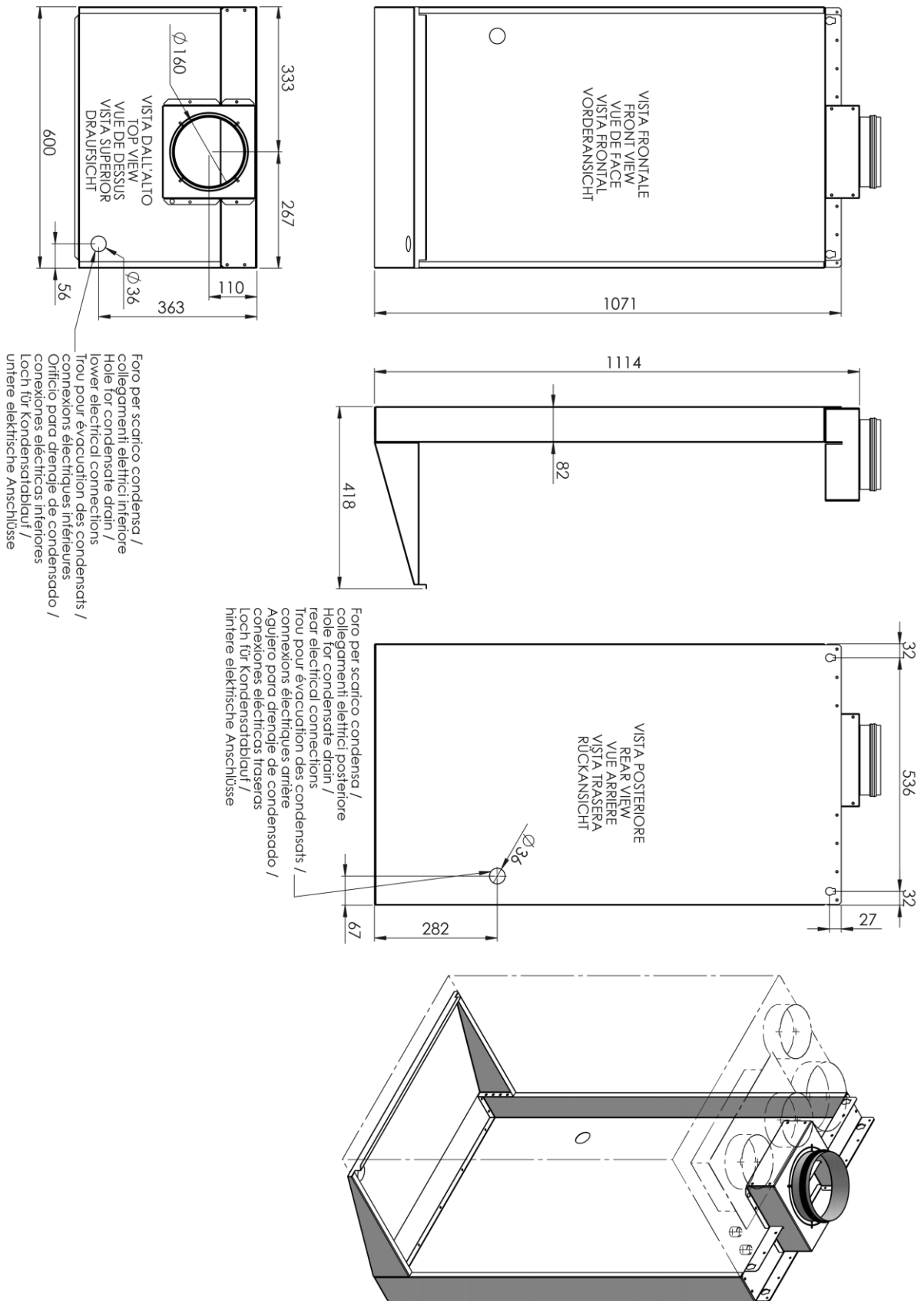

**1.7 REV 035**

**1.7.1 Dimensionale REV 035 (tutte le versioni)**

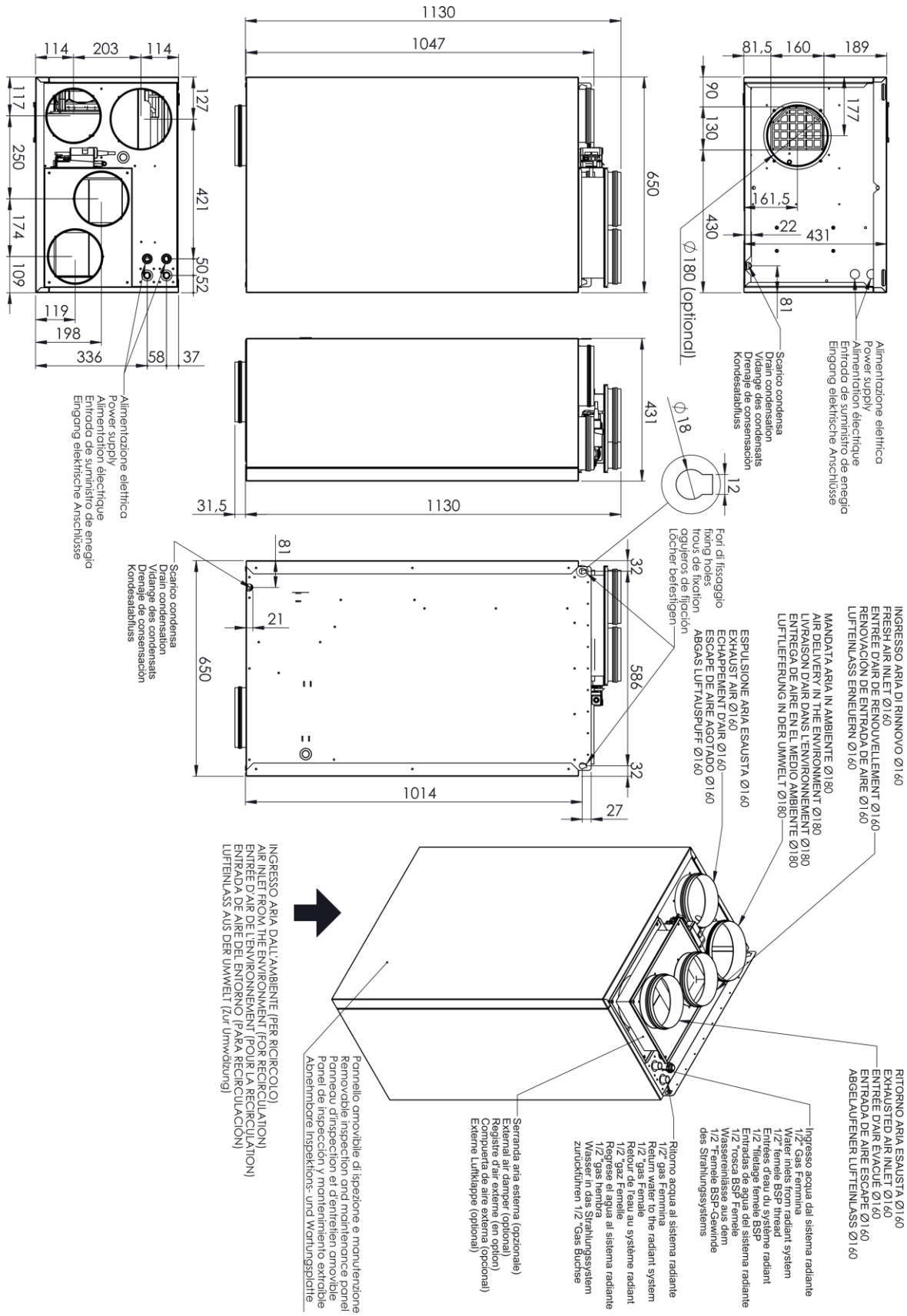

1.7.2 Dimensionale plenum ricircolo REV 035

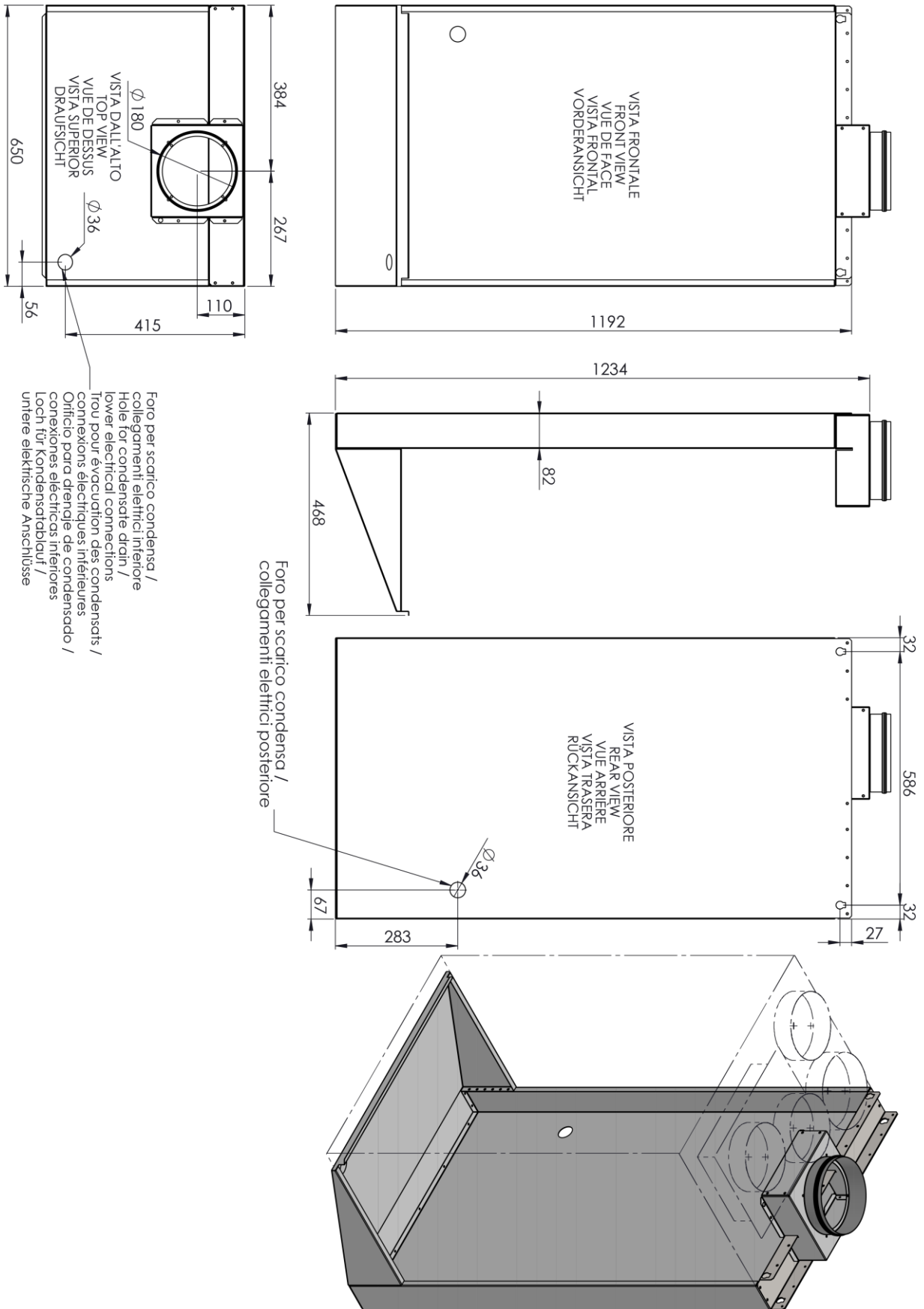

**1.8 REV 050 e REV 070**

**1.8.1 Dimensionale REV 050 e REV 070 (tutte le versioni)**

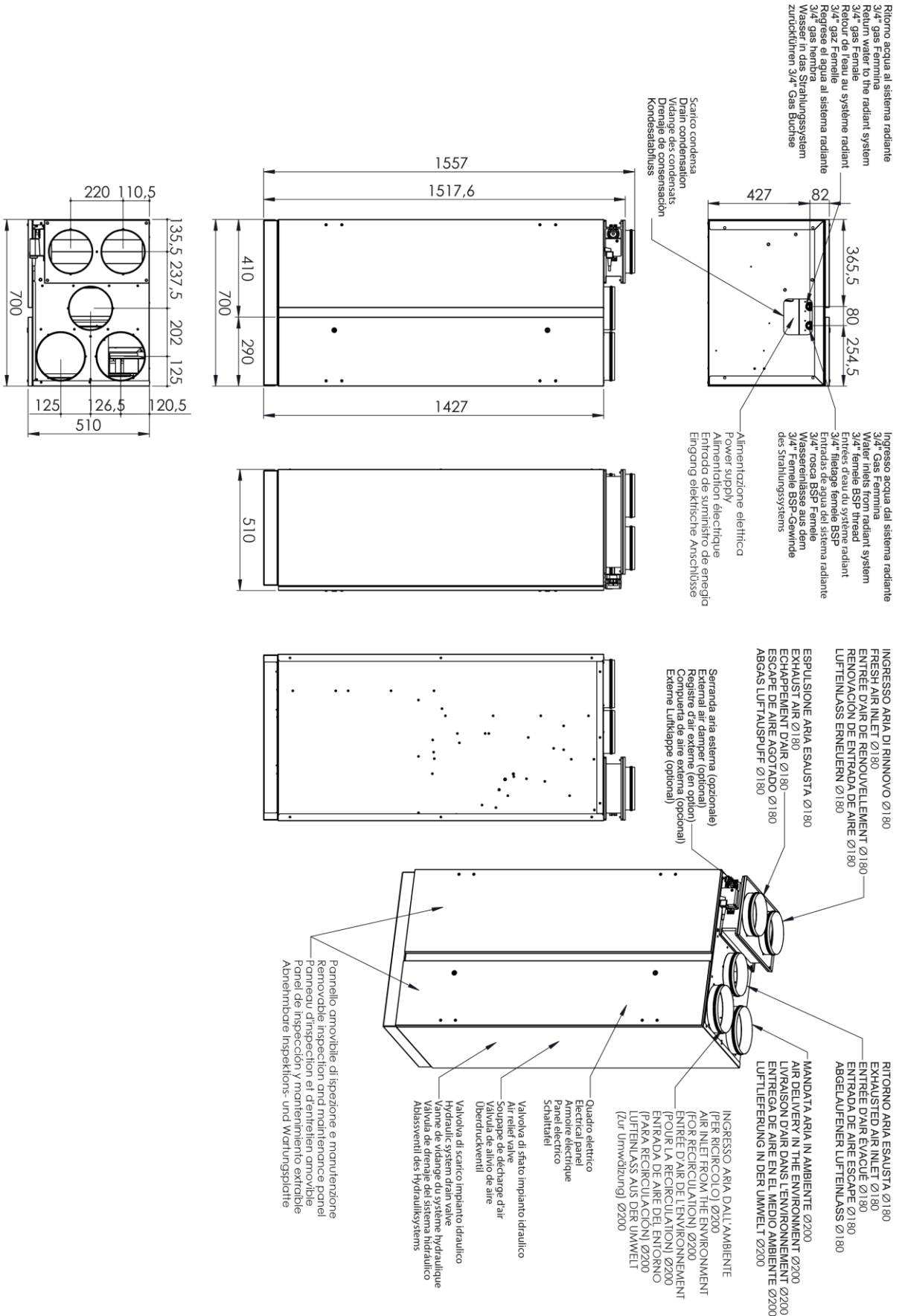



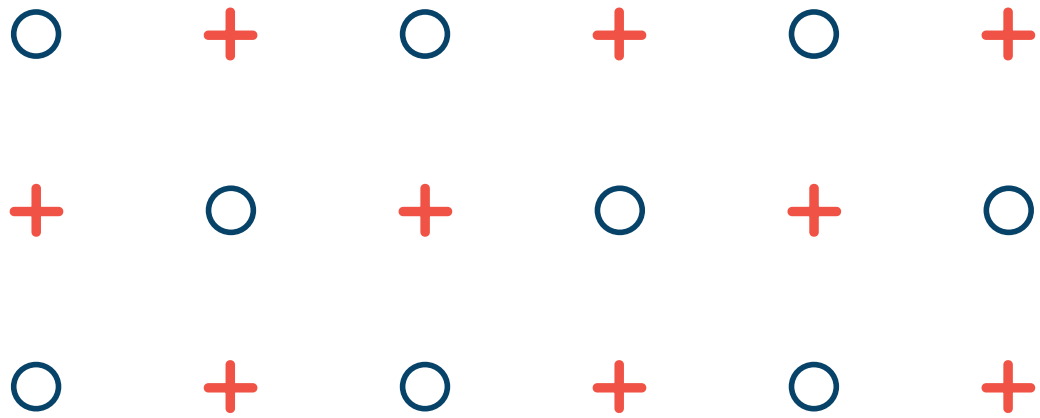

**NUCLEO PLUS S.r.l.**  
Sistemi energetici ibridi

P: +39 0422 303411  
E: [info@nucleoplus.it](mailto:info@nucleoplus.it)  
W: [www.nucleoplus.it](http://www.nucleoplus.it)

Viale della Repubblica, 235  
31100 - Treviso